

MELTRIC Corporation

The best in industrial wiring devices



At MELTRIC Corporation, our only business is electrical plugs and receptacles. We are focused on providing our customers with the best overall value by offering the safest, highest quality and most reliable plugs and receptacles, and by backing them with outstanding service and support.

Product Technology & Safety

The technology behind MELTRIC's products was developed specifically to address the shortcomings and safety hazards common with pin & sleeve type plugs and receptacles. In 1952, following the observation of an accident with a pin and sleeve device, Gilles Marechal devised the concept of combining the advantages of silver-nickel butt contacts and the load making and breaking capabilities of a switch with the convenience of a plug and receptacle. Shortly thereafter, the first of these products was born. MELTRIC licensed this technology in the early 1980's and has been supplying its products to North American customers ever since.

Value

With their unique features and capabilities, MELTRIC products provide users with a safer and more reliable product than competitive pin and sleeve devices. MELTRIC's butt-style contacts provide longer operating lives, optional integral pilot contacts reduce the need for additional connectors and our switch-rated plugs and receptacles can eliminate the need for auxiliary interlocks and disconnect switches, helping users reduce equipment costs. These advantages, together with competitive pricing, short lead times, and 5-year warranty on electrical contacts, make MELTRIC's products the best overall value in the plug & receptacle/connector market.

Service & Support

MELTRIC backs its superior products with outstanding service and support. A network of over 150 sales associates and over 2000 distributor locations throughout the US, Canada and Mexico make access to our product easy.

MELTRIC's Customer Service group is trained to answer most questions on the spot and is located at our manufacturing facility in order to help streamline the order fulfillment process. Our engineering team stands ready to provide both application support and custom designed products incorporating MELTRIC and third party components into power distribution products tailored to meet your needs. Friendly and personal assistance is only a toll free call away at (800) 433-7642.

Many of MELTRIC's products are designed in a modular fashion, which permits cost effective stocking of components and quick final assembly of the product. Together with efficient order handling by Customer Service, this helps MELTRIC to provide the shortest lead times in the industry.

Quality

Quality is not just an inspection function at MELTRIC. Quality starts with intelligent designs, robust materials, clear procedures, process measurement and controls and effective communications. It is completed by the care, commitment and involvement of each of our employees.

MELTRIC is dedicated to the continuous improvement of all its critical production and support processes and is ISO 9001:2015 certified. MELTRIC designs and manufactures its products to exceed the requirements of applicable UL, CSA and IEC standards.



Worldwide Availability

Marechal Technology products are manufactured in North America, Europe, South Africa and Australia. MELTRIC supplies product directly from its factory in Franklin, Wisconsin to customers in the United States, Canada and Mexico. For customers outside of North America, product is provided through other Marechal Electric Group companies and sales agents.

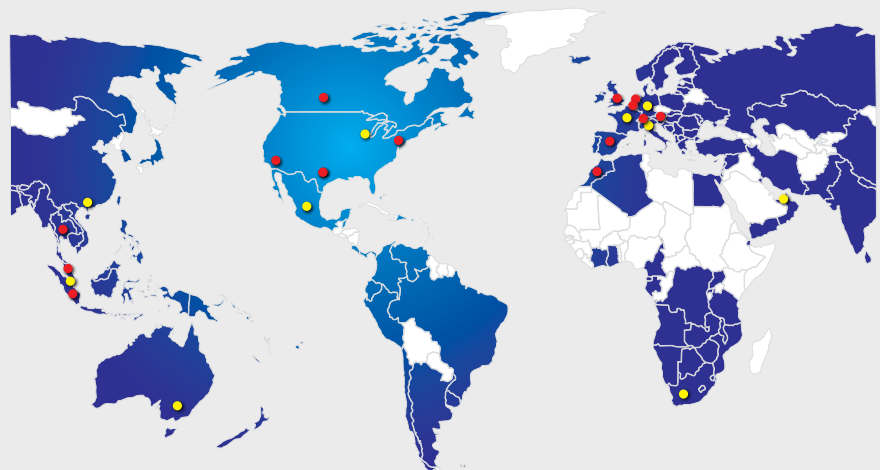

- SALES OFFICES & MANUFACTURING PLANTS
- COMPANY SALES PRESENCE
- SALES AGENTS & DISTRIBUTORS

MELTRIC PRODUCT FEATURES...



Spring-Loaded Butt Contacts

MELTRIC products feature spring-loaded, butt contacts similar to those used in contactors and switchgear. These contacts have numerous advantages, which help improve electrical performance and user safety relative to pin and sleeve contacts or the arcuate contacts used in twist-type devices.

Butt-style contacts ensure a very positive and consistent connection. The spring-loading of these contacts, which is accomplished with coil springs, provides a desirably high contact force that remains constant over thousands of operations. In addition, it automatically compensates for any wear and/or deviations in contact length resulting from manufacturing tolerances.

This is a critical point, as contact force is a key determinant of the quality of a contact. As the accompanying chart demonstrates, contact resistance increases as contact force is reduced. Higher contact resistance generates more heat

and oxidation, both of which contribute to the deterioration of the contact. This is a problem with pin and sleeve and arcuate type contacts because their contact force varies with manufacturing tolerances and is reduced due to wear that occurs with normal use.

Most MELTRIC contacts close with a self-cleaning wiping action. When the contacts initially mate, they are slightly offset. In completing the connection, the plug contacts are rotated across the receptacle contacts, helping to remove deposits from the contact surfaces.

In conjunction with the spring-loaded casings used on many MELTRIC products, the spring-loaded contacts ensure a quick breaking of the connection that is independent of the motion of the user. By contrast, the disconnection speed of pin and sleeve and twist-type devices is dependent upon the motion of the user.

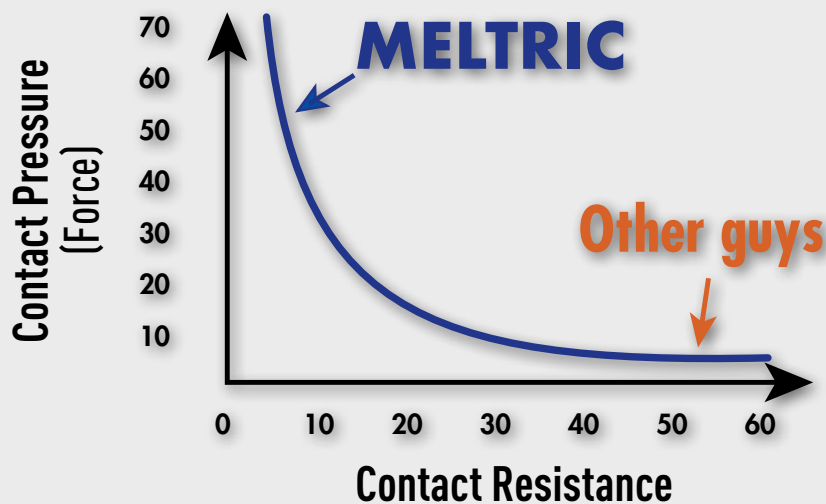

...AND BENEFITS

Silver-Nickel Contact Material

MELTRIC uses solid silver-nickel (85%/15%) contacts. The silver-nickel material has significant advantages over the brass contacts commonly used on competitive devices.

Silver has very low initial contact resistance and is not negatively affected by oxidation. This helps to give it excellent electrical properties that are maintained even at high temperatures and after tarnishing. Nickel is a much harder material and contributes excellent mechanical properties. The combination of silver and nickel results in a contact material that has both superior electrical capabilities and excellent resistance to wear. Silver-nickel only welds at extremely high pressure and temperature, and thus, also withstands arcs very well. These features make silver-nickel a commonly used contact material by switchgear manufacturers.

By contrast, the brass material used in most competitive plug and receptacles has much higher initial contact resistance and is negatively affected by oxidation. In an oxidized state, the contact resistance of brass is more than 20 times higher than that of silver-nickel. In addition, brass is a soft material that wears rapidly. In use, brass pin and sleeve and arcuate contacts suffer from the combined effects of the limitations of the material and the design. As oxidation and wear induced reductions in contact force occur, contact resistance increases. This increases operating temperature, which causes further oxidation and wear, perpetuating a vicious cycle of degradation. Brass is not arc resistant and is not suitable for making and breaking under load.

Dead Front Construction

Most MELTRIC products feature dead front construction, which greatly enhances safety by eliminating any unintended access to live parts. On most MELTRIC products, the dead front is accomplished with a safety shutter that can be opened only by an appropriate mating plug. The live receptacle contacts can only be accessed by the plug, after its insertion into the receptacle. The design of the product also ensures that the plug contacts are dead before the user can remove the plug from the receptacle.

By contrast, pin and sleeve and twist-type devices do not have a safety shutter. Access to live receptacle contacts is possible, and on some devices the plug contacts may be live and accessible when the plug is being removed.



MATERIAL	CONTACT		RESISTANCE
	NEW	OXIDIZED	
SILVER	6 $\mu\Omega$	25 $\mu\Omega$	
SILVER-NICKEL	23 $\mu\Omega$	60 $\mu\Omega$	
COPPER	29 $\mu\Omega$	400 $\mu\Omega$	
BRASS	370 $\mu\Omega$	1400 $\mu\Omega$	



MELTRIC PRODUCT FEATURES...

Push-Button Circuit Disconnection

To disconnect most MELTRIC products, the user simply needs to depress the pawl. This causes the circuit to be disconnected and the plug to be ejected to its rest (off) position in the receptacle. If desired, the user can then remove the plug from the receptacle by rotating it slightly and then withdrawing it. This mode of operation ensures that it is only possible to remove the plug after its contacts have been deenergized.



Enclosed Arc Chambers

The contacts on most MELTRIC products make and break within enclosed arc chambers. This ensures that the arcing which normally occurs during the making and breaking of the contacts is contained inside the device. This greatly enhances safety and avoids potential injury to users and/or harm to the outside environment.

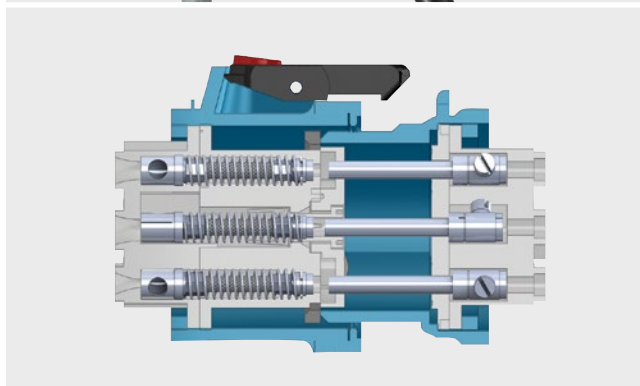

Optional Auxiliary/Pilot Contacts

Many MELTRIC products are available with optional auxiliary/pilot contacts. These integral pilot contacts allow users the convenience and flexibility of controlling auxiliary equipment, monitoring parameters (such as motor temperature), and/or communicating alarms through the same plug and receptacle used to supply power to the equipment. Because the pilot contacts are integral, they also facilitate the rapid change-out or reconfiguration of equipment by eliminating the need for hard wiring or multiple plug connections.

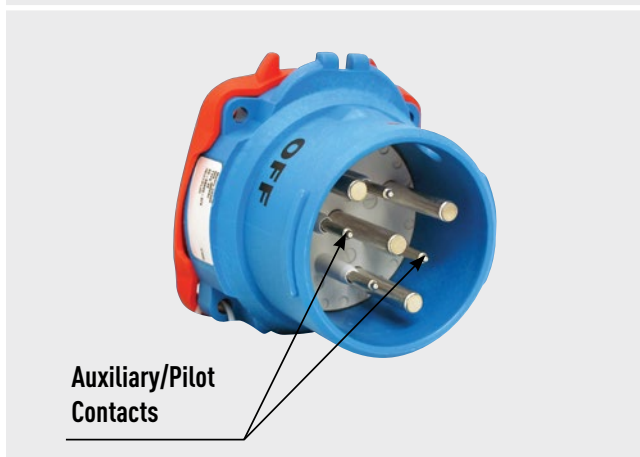

Automatic Watertightness

On most pin and sleeve devices, an additional plastic ring must be tightened in order to ensure the achievement of rated watertightness. Users frequently fail to do this, resulting in leakage. MELTRIC solves this problem with its DS and DSN Switch-Rated plugs and receptacles, which achieve their rated watertightness of up to Type 4X/IP69k simply by mating the plug with the receptacle. After the removal of the plug, rated watertightness is maintained for the receptacle by simply closing the lid.

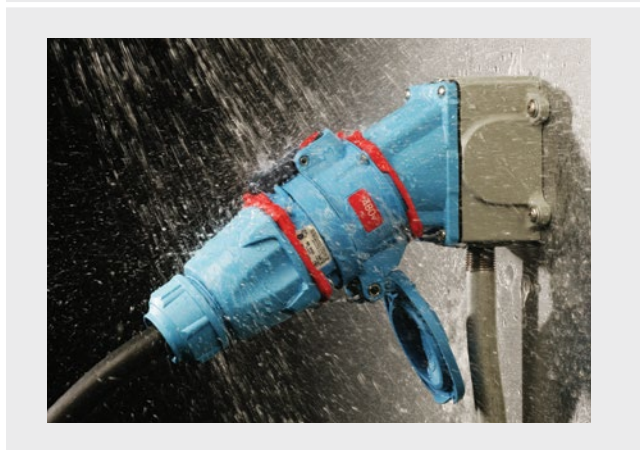

...AND BENEFITS

Spring-Assisted Terminals

The loosening of terminal screws is a common cause for failure on standard plugs and receptacles. MELTRIC provides a more permanent and secure connection with its unique and patented spring-assisted terminal design.

As the terminal screw is tightened against the conductor, the associated pressure expands the split terminal body, causing a spring ring surrounding the terminal to deform into an elliptical shape. The natural tendency for the spring ring to return to its original size and shape ensures that a constant pressure is maintained on the conductor. This allows the terminal to effectively compensate for strand settlement and conductor yield, due to cold flow of the material, and provides superior resistance to vibration, shock and thermal cycling.

Lockout-Tagout Capability

Most MELTRIC plugs and receptacles facilitate compliance with OSHA lockout-tagout requirements. Only a lock or lockout hasp and tag are needed to ensure that the plug is properly locked out and tagged out. Additional mechanisms are not required because the lockout provision is integral to the device – it is always available when you need it. On most models the lockout provision is a simple 5/16" hole in the plug shroud that facilitates the insertion of a typical padlock or lockout hasp which prevents the plug from being inserted into a receptacle.

An optional provision for locking out MELTRIC receptacles is also available. In most cases this is accomplished via a specially machined hole in the receptacle casing which allows insertion of a padlock to secure the receptacle lid in a closed position. This same optional provision can be used to prevent removal of the plug if desired.

By comparison, in order to lockout most competitive pin and sleeve type plugs, an additional third-party 'lockout shield' or 'plug cap' is required. These devices can be expensive and are often times lost, broken, or not available when you need them.

Modular Construction

Due to the robust construction of MELTRIC devices, the need to replace worn parts is rare. However, should they be required, parts are readily available and reasonably priced. The modular construction of most MELTRIC devices enables easy replacement of parts in the field.

